

# Fixed Showerhead

## 5 Year Warranty Terms & Conditions:

In the unlikely event that you should experience any defect in the materials or workmanship of your new Abode product within FIVE years of purchase, the purchaser's sole remedy shall be the replacement (at the manufacturer's discretion) of all or any part of the product that is defective. Valves are guaranteed for a period of FIVE years from purchase. Decorative surface finishes and O-rings are guaranteed for ONE year from the date of purchase provided that our advice concerning care has been observed and no scouring agents have been used.

This is provided that the product has been used for normal domestic purposes in the UK and that the care, installation and maintenance instructions have been observed. The warranty extends to the original purchaser only. You should retain a copy of your dated invoice as proof of purchase to validate any claims under this warranty.

Marks and scratches caused by improper installation or accidental damage are not covered by this guarantee. Neither are shade variations or any damage or defect caused by incorrect installation or abuse of the fitting.

## Product Care Instructions:

To maintain the appearance of this product, ensure that it is regularly cleaned only using a clean, soft damp cloth. A solution of warm water and a mild liquid detergent may be used where necessary, and then the fitting rinsed thoroughly and wiped dry. Any other cleaning action or cleaning products will invalidate your warranty.

Abrasive cleaners, scouring cleaners, limescale cleaners and acidic cleaners **must not be used** under any circumstances. Avoid contact with all solvents (including chlorinated solvents, ketones or acetones as these may result in surface deterioration or etching). Also avoid contact with any harsh household chemicals such as bleach cleaners, drain cleaners, rust removers, paint strippers and toilet bowl cleaners, toothpaste, mouthwash, bar keepers friend or Brasso.

If the product has a spout aerator it can be unscrewed and cleaned periodically in warm water to maintain flow. Sprayheads have 'rub clean' nozzles to reduce any limescale build up. If the product has a meshed inlet seal this will need cleaning to maintain flow periodically.

As we are continuously improving and developing our products range, finishes & colours, in the event of a valid claim, we may not be able to provide an identical replacement for the defective product throughout the warranty period. Where an identical product is no longer available, we will supply the nearest equivalent from our then current product range. In assessing your claim, we must be given the opportunity to inspect the product as installed prior to removal. Any product returns must be packaged carefully as received and complete.

No other warranties, express or implied, are made, including merchantability or fitness for a particular purpose. Under no circumstances shall the manufacturer be liable for any loss or damage arising from the purchase, use or inability to use this product, or for any special, indirect, incidental or consequential damages. No liability is accepted for consequential damage to other household fixtures, fittings or furnishings arising from this claim, even if attached to the product. No installer, dealer, agent or employee of Abode has the authority to modify the obligations or limitations of this warranty.

The logo for Abode, featuring the word "abode" in a lowercase, sans-serif font. The letter 'a' is stylized with a vertical line extending upwards from its top.

**Please leave these instructions for your customer.**

## Installation Preparation:

All parts should be removed from their packaging and inspected for any transport damage and completeness prior to installation; you should read these instructions throughout before commencing installation.

We do not accept responsibility for problems that may occur through improper installation. Always ensure you have sufficient hot and cold water pressure available to allow correct function before specifying or installing this product.

We strongly recommend installing particle filters and isolation valves to both the hot and cold supply pipes in an accessible position. This will help to prevent premature failure of the any product valves and ease any future maintenance. All serviceable parts should be given suitable access to allow easy future maintenance.

Shut off your water heating system and ensure that your mains stopcock is closed. Ensure both the hot and cold water supplies are isolated before commencing installation.

When preparing the piping run to this product arrange the hot pipe to be received to the left hand side of the product when viewed from the front.

You should ensure that both the product and required fittings will fit into the depth and area of the mounting surface available before installation. Roughly assemble the product and plumbing connections to establish the required sizes.

Before installing the new fitting **it is essential that you thoroughly flush through the supply pipes** in order to remove any remaining solder, swarf or impurities from your system. Failure to carry out this simple procedure could cause problems or damage to the workings of the fitting and invalidate the warranty.

## Installation Guidance:

Key	Description	Qty	Notes
A	Shower arm / Wall outlet	0	1/2" male connection
B	1/2" seal	1	Mesh filter dependant on model
C	Locking snodo	1	1/2" female inlet connection
D	Showerhead	1	
E	Lower seal	1	
F	Grub screw	*	*Allen Key (G) and Grub screw (F) only applicable dependant on model.
G	Allen key (size 1.5, 2.5 dependant on model)	*	
<p><b>*Note: A 9 red litre flow limiter is fitted between parts (C &amp; B) on selected models. This can be removed to improve the flow rate of the shower at lower pressures.</b></p>			

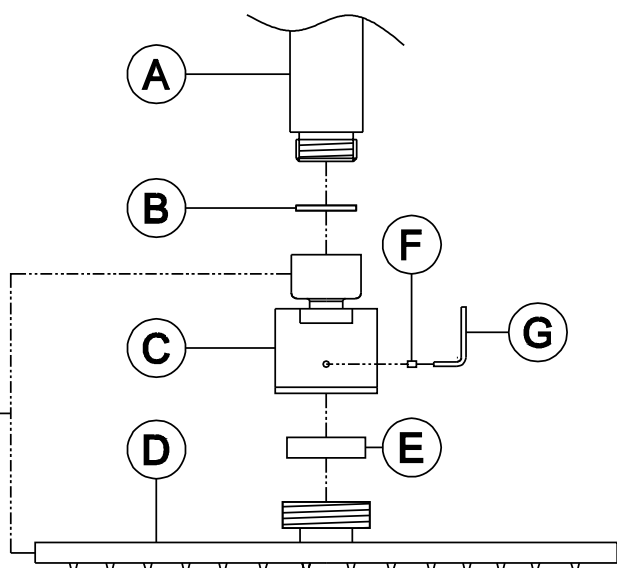

## **Installation Instructions:**

1. Loosely assemble the product as per the exploded drawing, note some parts may be supplied pre assembled depending upon the model chosen. Do not disassemble any assemblies unless required to complete installation.
2. Attach any plumbing outlet connection (A) as shown.
3. Attach any mounting fixings (B-E) as indicated; secure the product firmly to the mounting surface.
4. Connect any inlet connections (C) to the plumbing outlet connection (A).

## **After installation:**

Once you have visually checked the installation of the new product and all connections, ensure that all other fittings are closed except the new product which should be left open.

Turn on your water heating system and ensure that your mains stopcock is open. Reconnect both the hot and cold water supplies to this fitting.

Check the function of flow and function of hot, cold and mixed water through all outlets. If the product has thermostatic function test the maximum output temperature.

Turn off the product and check carefully for any leaks around all connections on the fitting and adjoining plumbing. If possible return to the installation after a longer period to double check for slower leaks. If pressure testing equipment is available check the installation to the maximum recommended pressure.

Clean the product to remove any marks created during installation as instructed, then place a bag over the product to protect the product finish until it is ready for use.

Check that the product is sealed against water ingress to the mounting surfaces.

## Important Technical Data:

Minimum water pressure, varies by model, see [www.abodedesigns.co.uk](http://www.abodedesigns.co.uk)

Maximum operating pressure 5 bar\*

Maximum recommended hot water temperature 70°C

\*Note: If these pressures or temperatures are exceeded, even for short periods, damage can result. In these instances a pressure reducing valve or TMV should be installed.

For manual mixing products we recommend the installation of a separate TMV2 product to reduce the risk of accidental scalding.

All thermostatic products should be tested and cleaned at least once a year.

When drilling or preparing walls take care not to disturb existing water or electrical supplies that may be buried within the wall.

Supply pipes should maintain the maximum diameter until immediately before the fitting.

Hot and cold supply pressures should be as closely balanced as possible for best results. The differential between the hot and cold water supply temperatures should be sufficient to allow correct mixing function.

Where hot and cold supply pressures are greatly imbalanced flow restricting valves or pressure reducing valves should be installed on the supply with the greater incoming pressure.

Abode products are either WRAS approved or manufactured in accordance with recognised European standards. Please ensure that your Abode product is fitted in accordance with Local Water Byelaws. Where hot and cold water mix within any product, then suitable non return valves should be installed to the hot and cold supplies to prevent backflow.

Whilst assembling this product take care not to accidentally loosen any screwed assemblies. PTFE tape can be used to ensure watertight joins on threaded connections, do not over tighten connections or allow pipes to be twisted or folded.

The installation should be periodically checked for damage, if the property is left unattended for a prolonged period we recommend isolating water supplies.

All errors and omissions excepted.

abode

Unit L, Zenith Park, Whaley Road, Barnsley, S75 1HT.

Tel: 01226 283434 Fax: 01226 282434

**Manufacturers Reference**

©Abode 04/2020

[www.abodedesigns.co.uk](http://www.abodedesigns.co.uk)